

## SP-415 FINISH FOR PLASTIC BOTTLES

mm	T <sub>6</sub> /		E <sub>6</sub> /		H <sub>1</sub> /		L	S		I <sub>485</sub> /	W <sub>3</sub> /	HELDX ANGLE β	CUTTER DIA	THD'S PER INCH
	MAX	MIN	MAX	MIN	MAX	MIN		MAX	MIN					
13	.514	.502	.454	.442	.467	.437	.306	.052	.022	.218	.045	3°11'	.375	12
15	.581	.569	.521	.509	.572	.542	.348	.052	.022	.258	.045	2°48'	.375	12
18	.704	.688	.620	.604	.632	.602	.429	.052	.022	.325	.084	3°30'	.375	8
20	.783	.767	.699	.683	.757	.727	.456	.052	.022	.404	.084	3°7'	.375	8
22	.862	.846	.778	.762	.852	.822	.546	.052	.022	.483	.084	2°49'	.375	8
24	.940	.924	.856	.840	.972	.942	.561	.061	.031	.516	.084	2°34'	.375	8
28	1.088	1.068	.994	.974	1.097	1.067	.655	.061	.031	.614	.094	2°57'	.500	6

### NOTES:

1. Dimension "H" is measured from the top of the finish to the point where diameter T, extended parallel to the centerline, intersects the top of the shoulder.
2. A MINIMUM OF 2 — Full turns of thread shall be maintained.
3. Use of bead is optional. If bead is used, bead dia. and "L" MINIMUM must be maintained.
4. Hole dia. "I" to be measured through full length of finish unless otherwise specified.
5. Concentricity of "I" Min. with respect to diameters "T" and "E" is not included. "I" Min. is specified for filler tube only.
6. "T" and "E" dimensions are the average of two measurements taken 90° apart. The limits of ovality will be determined by the container supplier and container customer, as necessary.
7. All dimensions are in inches unless otherwise indicated.

*To the best of our knowledge the information contained herein is accurate. However, The Society of the Plastics Industry, Inc., assumes no liability whatsoever for the accuracy or completeness of the information contained herein. Final determination of the suitability of any information or material for the use contemplated, the manner of use and whether there is any infringement of patents is the sole responsibility of the user.*

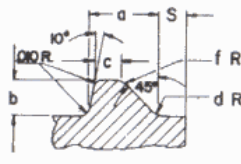
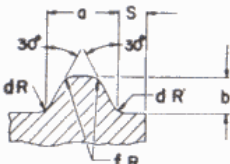
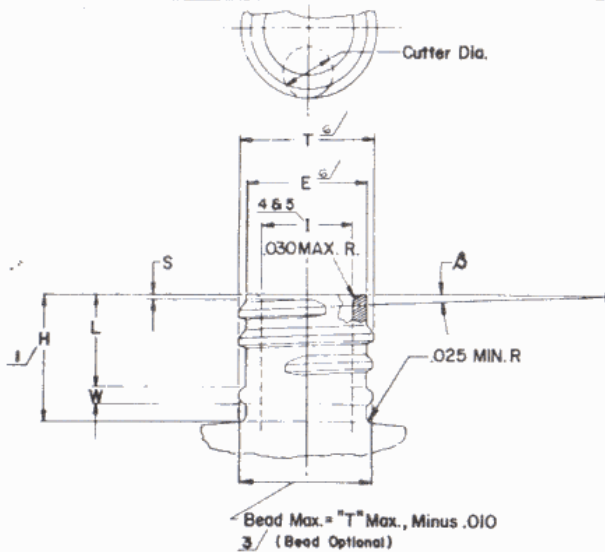

ALL PURPOSE THD. (Plastic or Metal Caps)				
THDS/IN	a	b	d	f
6	.094	.047	.020	.020
8	.084	.042	.020	.020
12	.045	.030	.015	.005

MODIFIED BUTTRESS THD. (Plastic Caps)					
THDS/IN	a	b	c	d	f
6	.094	.047	.039	.030	.030
8	.084	.042	.035	.030	.030
12	.051	.030	.016	.020	.008

### THREAD CROSS SECTIONS

Example thread nomenclature:

"L" Style : L22SP415  
"M" Style : M22SP415